

# Freckles

Skill level:  
Intermediate



Fabric Designed by Tula Pink  
Project by Tula Pink

<b>Technique:</b>	Piecing & Patchwork
<b>Brand:</b>	FreeSpirit Fabric
<b>Crafting time:</b>	Longer Term

Tula Pink's newest fabric collection is a fantasy adaptation about a dynamic queen based on the life of Elizabeth I of England. It's both quirky and elegant in a way that only Tula Pink can achieve!

**Finished Size of Project:** 62" x 72"  
(158cm x 183cm)

### FreeSpirit Elizabeth Collection by Tula Pink

#### Fabric Requirements:

(A) Fat Quarter Bundle	1 bundle (of 25 fat quarters)
(B) CSFSESS.AMAZO	3 yards (2.74m)
(Binding) PWTP069.TARTX	2/3 yard (0.61m)
(Backing) PWTP066.TARTX	4 1/2 yards (4.12m)

#### Additional Requirements:

Sewing Machine  
Rotary cutter/mat/plastic ruler  
Iron/pressing board  
Basic sewing supplies  
70" x 80" quilt batting (178cm x 203cm)  
Template plastic

[makeitcoats.com](http://makeitcoats.com)  
[freespiritfabric.com](http://freespiritfabric.com)

FS0286

## Cutting Instructions

**Note:** WOF - Width of Fabric, LOF – Length of fabric

### Fabric A, cut:

(120) Template 1 cut from assorted fat quarters

### Fabric B, cut:

(120) Template 2 *(See Figure 1 on how to nest the templates for cutting)*

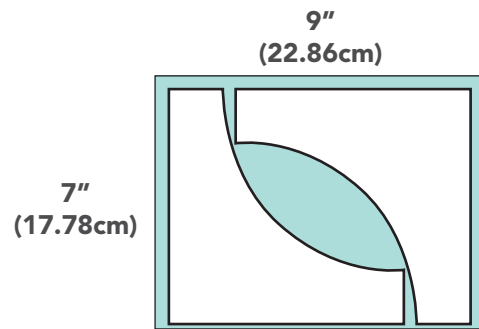

Fig. 1

### Fabric C, cut:

(7) 2 ½" x WOF (6.35cm x WOF)

### Backing Fabric, cut:

(2) 70" x WOF (178cm x WOF)

## Sewing Instructions:

1. Select (1) Template 2 unit and (1) assorted Fabric A Template 1 unit.
2. Find the center of each template. Pin the (2) units together, starting in the center of each template out to the edge, gently easing the curves together.
3. Sew the pieces together to make (1) corner unit. Repeat to make (120) corner units total.
4. Sew (4) corner units together to make (1) 12 ½" (31.75cm) block. (Use the quilt picture as a guide to block selection or pick your own.) Repeat to make (28) blocks total.
5. Sew (2) corner units together to make (1) half-block. Repeat to make (4) half-blocks total.

## Quilt Assembly:

*(Follow the Quilt Photo while assembling the quilt.)*

6. Sew (6) blocks together to make Column One. Repeat to make Columns Three and Five.
7. Sew (5) blocks and (2) half-blocks together to make Column Two. Repeat to make Column Four.
8. Sew the five columns together, in numerical order, to make the quilt top.

## Finishing:

9. Layer the backing, batting and quilt top. Quilt or tie as desired.

10. Prepare binding from seven 2 ½" x WOF (6.35cm x WOF) Fabric C strips. Sew strips together into one long binding strip. Press strip in half lengthwise.

11. Carefully trim backing and batting even with quilt top.

12. Leaving an 8" (20.32cm) tail of binding, sew binding to top of quilt through all layers matching all raw edges. Miter corners. Stop approximately 12" (30.48cm) from where you started. Lay both loose ends of binding flat along quilt edge. Where these two loose ends meet, fold them back on themselves and press to form a crease. Using this crease as your stitching line, sew the two open ends of the binding together right sides together. Trim seam to ¼" (0.64cm) and press open. Finish sewing binding to quilt.

13. Turn binding to back of quilt and blind stitch in place.

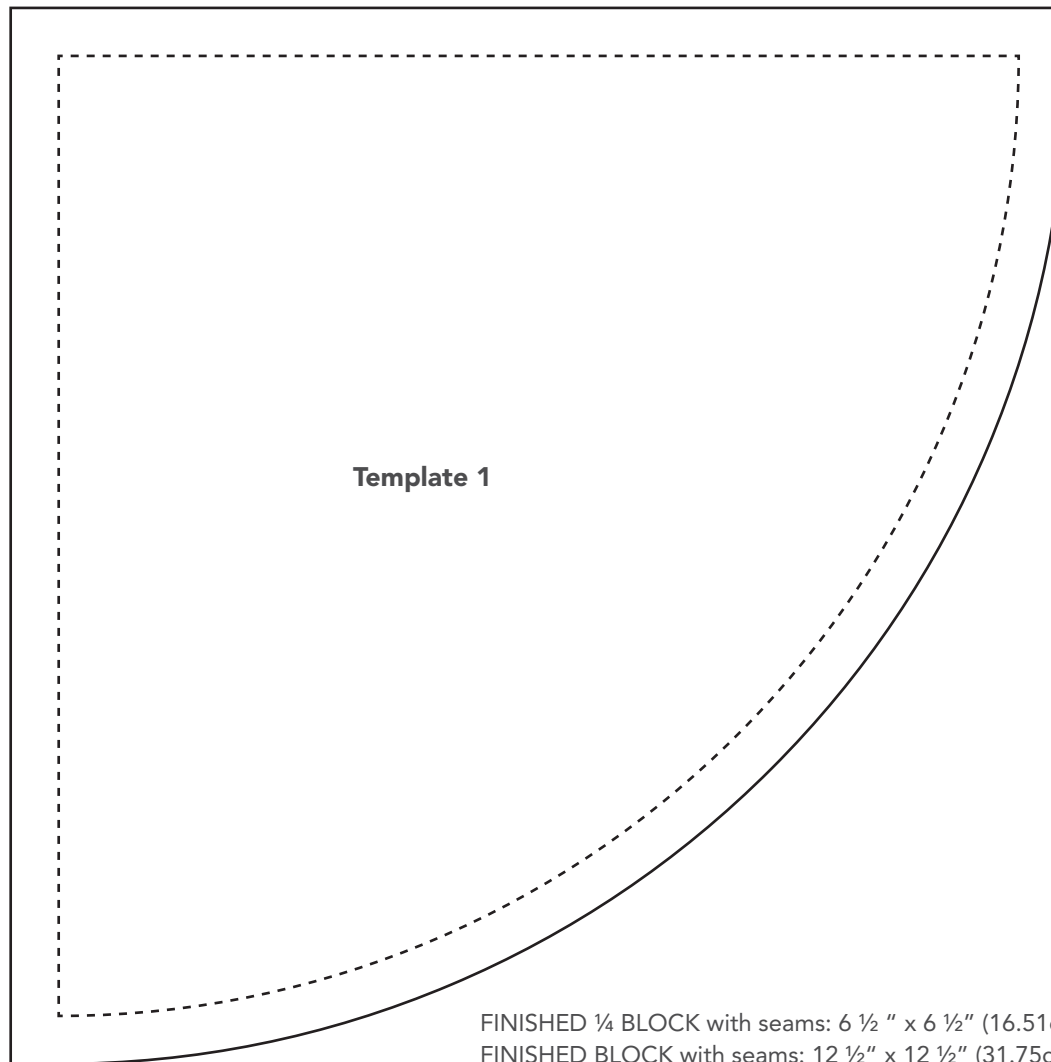

FINISHED ¼ BLOCK with seams: 6 ½" x 6 ½" (16.51cm x 16.51cm)  
FINISHED BLOCK with seams: 12 ½" x 12 ½" (31.75cm x 31.75cm)

FINISHED ¼ BLOCK with seams: 6 ½" x 6 ½" (16.51cm x 16.51cm)  
FINISHED BLOCK with seams: 12 ½" x 12 ½" (31.75cm x 31.75cm)

